

Features

- Meets or exceeds ASME/ANSI class 150 standard
- AWWA Lead Free Bronze construction
- Approved to NSI/ANSI 61 and 372
- Verticale Z plate type strainers with removable stainless steel screen for easy cleaning
- Removable drain plug

Application

Strainers are designed to be used in potable cold water systems. Working pressure should not exceed 150 PSI.

Operation

The AWWA recommends strainers be placed in the service line for Turbine or Compound meter service above 2" in diameter. The purpose of the strainer is to screen debris from the system that could cause damage by catching foreign objects before they reach the measuring element. These foreign objects can be introduced into the system from various events, such as maintenance of the system or scale build-up over time that breaks free. The strainer will also improve the velocity profile of the flowing water and minimize velocity distortion and turbulence from the system. These benefits maximize the meters' accuracy and longevity by eliminating debris and turbulence from the system.

Installation

The strainer must be installed upstream of the meter it is protecting. When installing the strainer, make sure that the top plate is accessible for removal during maintenance and cleaning of the strainer screen.

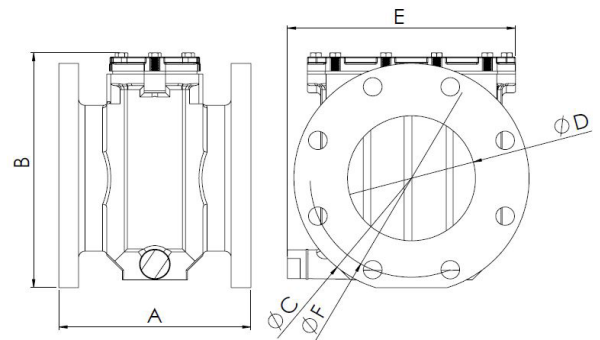

	3" Strainer	4" Strainer	6" Strainer
A	6.0	7.5	9.0
B	7.8	9.13	11.3
C	7.4	9.0	11.0
D	3.2	4.0	5.9
E	7.2	8.63	10.25
F	6.0	7.5	9.5

ALL DIMENSIONS ARE IN INCHES

